

# DISPLACER LEVEL SWITCH 100 One Stage Series

**EDW100** – Weather Proof Type

**EDX100** – Explosion Proof Type

The NEW-FLOW Displacer Level Switches are made to fit wide range applications such as pump control, waste water level and deep open tank. They are designed for high corrosive resistance and long service life. 100-Series are one stage control and easy to install.

## Technical Data

**Wetted Parts Material:** SS316, SS304 available

**Housing Material:** EDX- Aluminum alloy; EDW- SS316 or C.S with painting

**The Suitable S.G.:** ≥0.6

**Enclosure Housing:** EDX–Explosion Proof: EEx d II C T6; EDW–Weather Proof: IP65

**Micro Switch Rating (SPDT & DPDT Type):** 5A125VAC, 3A250VAC, 3A/30VDC, 0.4A/125VDC, 0.2A/250VDC

**Max. Temperature:** 250°C

**Float Size:** ø60mm x 160mm length; other size available upon request



## Switch Function

Dry Contact Micro-switch	1SPDT	
Hermetically Switch		
Dry Contact Micro-switch	(DPDT) 1SPDT X 2	
Hermetically Switch		

## Housing

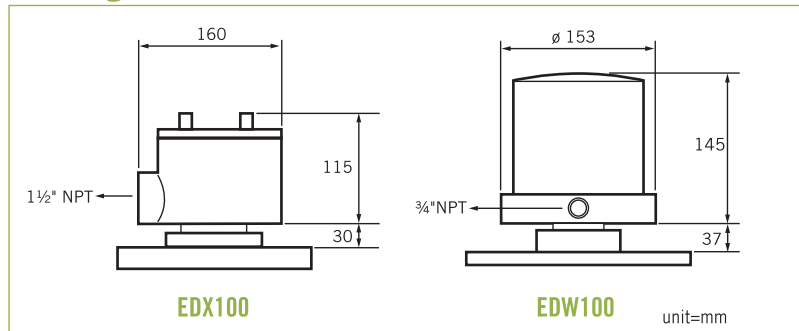

## Control

### Narrow Differential Model: 100

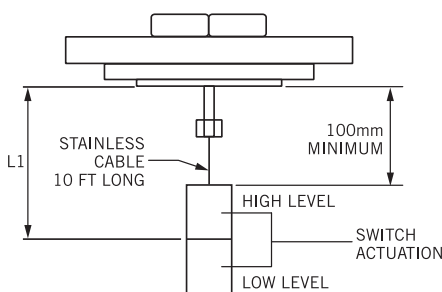

### Wide Differential Model: 101

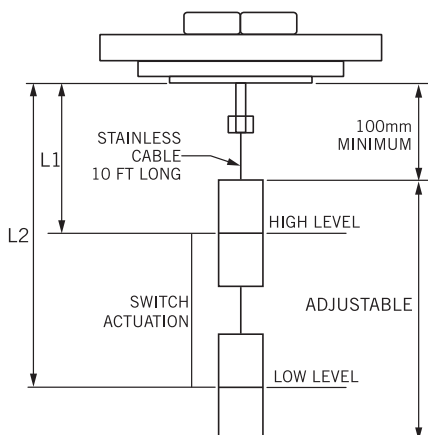

## Ordering Information

EDW / EDX	Code	Model
	100	Narrow differential
	101	Wide differential
	<b>Code</b>	<b>Housing Material</b>
	A	Aluminum alloy (only for EDX)
	B	SS316
	C	C.S with painting
	<b>Code</b>	<b>Process Connection Size</b>
	(1)	2 1/2"
	(2)	3"
	(3)	Option
	<b>Code</b>	<b>Process Connection Rating</b>
	(A)	JIS 10K
	(B)	JIS 20K
	(C)	ANSI 150#
	(D)	ANSI 300#
	(E)	PN16
	(F)	PN40
	(G)	Option
	<b>Code</b>	<b>Conduit Size</b>
	1	standard 1 1/2" NPT(F) with adaptor 3/4" NPT(F)
	<b>Code</b>	<b>Switch Function</b>
	A	Dry contact Microswitch
	B	Option
	C	Dry contact Microswitch
	D	Option
	<b>Code</b>	<b>Float Material</b>
	(1)	SS316
	(2)	SS304
	<b>Code</b>	<b>Wetted Parts Material</b>
	(A)	SS316
	(B)	SS304
	<b>Code</b>	<b>Sp. Gr.</b>
	(A)	1
	(B)	Other Sp. Gr.
	<b>Setting Point</b>	
		Please fill in the requested length
		L1=                      L2=
		L1=                      L2=